

Congratulations on your new Aduro H2 Stove!

To get the best possible experience and benefit from your new Aduro H2, it is important that you read the user manual thoroughly before you install your Aduro H2 and start using it. Errors or incorrect settings can cause hazardous conditions and/or poor operation.

For further information, please go to www.adurofire.com.

At the inside of the bottom front door you can find the production number, the serial number, and the code for the Aduro Hybrid App. We recommend that you note down these numbers in the box below before mounting the stove. For the purposes of the guarantee and for other enquiries, it is important that you are able to quote the production number as well as the serial number.

Production number:
Serial number:
Code for the Aduro Hybrid App:

Enjoy!

HOW TO SUCCEED WITH YOUR NEW HYBRID STOVE

In our customer service center [Aduro Customer Service](#) you will find tips and tricks on how to succeed with your new Aduro Hybrid stove. Find us [here](#) and make the most of your Aduro stove. Moreover, we recommend registering your Aduro Hybrid in [Aduro Cloud](#) so you do not miss important information and alarms regarding your stove.



1. General

1.1 Compliance

Aduro H2 complies with the European Directive Ecodesign 2022, the EN13240 and EN14785 European standards as well as the NS3058 Norwegian standard and is thereby approved for installation and use in Europe. At the same time, the manufacturing process is subject to external quality control. DoP (Declaration of Performance) and DoC (Declaration of Conformity) can be downloaded at www.adurofire.com/download.

Aduro H2 adheres to the following directives: EMC DIRECTIVE 2014 30 EU, LVD DIRECTIVE 2014 35 EU, 2006 42 Machinery Directive. The Wi-Fi module has been approved according to CMIIT ID: 2016DP3252. All local regulations including those referring to national and European standards must be complied when installing the stove.

1.2 Warnings and safety precautions

- The lid to the pellet container must always be closed during use.
- When using wood logs in periods without electrical power you must always look after the stove, as security sensors are not active.
- The product and the cladding must be stored in a dry place and must not be exposed to weathering.
- Disconnect the product from the power supply before performing any maintenance operation.
- Improper use or poor maintenance of the product can cause hazardous situations.
- Do not place flammable materials on the stove to dry. Keep any flammable materials in safe distance to the stove according to the manual.
- Failure to have the annual stove maintenance performed by qualified personnel, e.g. an authorized technician, will result in the loss of the warranty.
- Installation, start-up visits, tests, and maintenance must be carried out by authorized and qualified personal.
- Do not operate the product if the glass is broken.
- Turn the product off in the event of a fault or malfunction.
- If one of the following alarms "dropshaft hot", "shaft sensor defekt" or "external auger output defect" is activated, do not use the stove - not with firewood either - until the fault has been rectified, as this may damage the stove. Using the stove anyway can lead to a very costly repair of the stove. If you want to fix the error yourself, then follow this FAQ: <https://aduro.microsoftcrmportals.com/en-us/knowledgebase/article/KA-01157>. If it is very important to you to get heat from the stove, even if there is a fault in the external auger, the internal auger must be removed and the fall shaft (shaft between the two augers) must be emptied of pellets. Remount the internal auger. The stove can now be used with firewood until a technician can rectify the fault.
- The doors on the stove must remain closed when it is not used.
- Do not put any fuel or anything else other than wood pellets in the container. We do not recommend a particular type of pellets, but they must be of a good quality, approved and comply with European standards. Our experience, however, says that bright pellets burn better than dark pellets. It is important that you only use dry pellets.
- The product must be powered by an electrical system that is equipped with an earthing stove.
- In the event of fire in the chimney, turn off the device, disconnect it from the main electricity, close the air inlets and do not open the door and then contact authorities for help.
- This stove can be used by children aged 12 years and above. Children must not play with the stove. Children without supervision shall not carry out cleaning and maintenance.

- Persons with reduced physical, sensory or mental capabilities or lack of experience and knowledge can use the stove if they have been given supervision or instruction concerning use of the stove in a safe way and understand the hazards involved.
- The installation of the stove must be in accordance with legislation and regulations in the region or state.
- Any flammable objects must be kept at a safe distance from the product due to fire hazard in accordance to the product manual.
- Use only the fuel recommended by Aduro A/S. It is forbidden to use any liquid fuels and bioethanol fluids for lighting/ rekindle charcoal or pellets.
- Some of the surfaces on the product can get very hot (door, handle, glass, smoke outlet pipes, etc.). Avoid therefore direct contact with these parts, without adequate protective clothing or suitable tools, such as gloves with thermal protection.
- Accumulated and unburned pellets in the brazier after “failed start-up” or alarms must be removed before lighting again. Check that the cave is clean and positioned properly before lighting again.
- We recommend that you install a smoke detector in the room where the Hybrid stove is installed.
- If the smoke temperature exceeds 350 degrees, it can damage the gear motor.
- It is recommended to let the stove burn empty for pellets and clean it before a still stand period longer than 2 weeks – especially if the humidity is high.
- A yearly service visit is obligatory and crucial to the functioning and safety of the stove. See section 6.4.

Aduro A/S declines all responsibility for any damage which may be caused, directly or indirectly, to persons, animals, or objects as due to non-compliance with any provision specified in the manual, especially warnings regarding installation, use, and maintenance of the stove.

The responsibility for improper use of the product is entirely borne by the user and relieves the manufacturer from any civil and criminal liability. Tampering or unauthorized replacement with non-original spare parts could be hazardous for the operator’s safety and relieves the company from any civil and criminal liability.

1.3 Technical data

Aduro H2	Data
Nominal power	7.0 kW wood / 6.8 kW pellets
Heats	20-140 m ² / 2-9 kW. Wood 3-9 kW / Pellets 2-7 kW
Flue outlet	Ø15 cm top/rear
Fresh air supply	Ø7.8 cm external
Measurements (HxWxD)	120 x 50 x 50.8 cm
Height exhaust branch above floor level	117 cm
Distance from centre of exhaust branch to rear edge of stove	25 cm
Weight	135 kg
Material	Steel
Fuel	Wood and pellets Ø6 mm, max length 40 mm. Pellets in ENplus A1 quality.
Max wood length	39 cm
Convection stove	✓
Primary, secondary, and tertiary air supply	✓
Air-wash system	✓

Ash pan	✓
Ceramic igniter	✓
Energy efficiency	>81% wood/ >87% pellets
Energy efficiency index	122,3
Energy efficiency class	A+
Chimney draft	According to EN13240: Constant draft of 12 PA – read chapter 4.1 for further information.
Maximum combustion amount per hour: - Wood - Auger performance – pellets per hour	Approx. 3.1 kg Approx. 1.5 kg
Heat rating in buildings with - Optimum insulation - Average insulation - Inadequate insulation	150 m ² 100 m ² 60 m ²
Electrical connection	230V / 50Hz
Pellet container capacity	Approx. 13 kg

1.4 Transportation

When taking your Aduro H2 home, please ensure that it travels in an upright position. The packaging must be disposed according to national rules regarding disposal of waste.

2. Installation of the Aduro H2

You are welcome to install your Aduro H2 yourself – but we strongly recommend that you consult your chimney sweep before you begin the installation. Your dealer can also provide you with installation advice. It is important to ensure that all local rules and regulations, including ones relating to national and European standards, are complied with when installing this device. Further, it is important to ensure that the fireproof tiles and the exhaust deflector in steel is placed correctly. Remember, it is your responsibility that rules in force are complied with.



You may not begin to use the Aduro H2 until it has been inspected and approved by your local chimney sweep.

2.1 Position of the hybrid stove/distance requirements

The new Aduro H2 must be installed in a suitable and physically possible position. You need to be sure that the position complies with local regulations. Distance requirements will only apply if the Aduro H2 is to be placed close to flammable materials:

Distance to flammable material (see also illustration below)			
Behind the stove	To the sides	Corner arrangement	To furniture
7.5 cm	40 cm	10 cm	100 cm

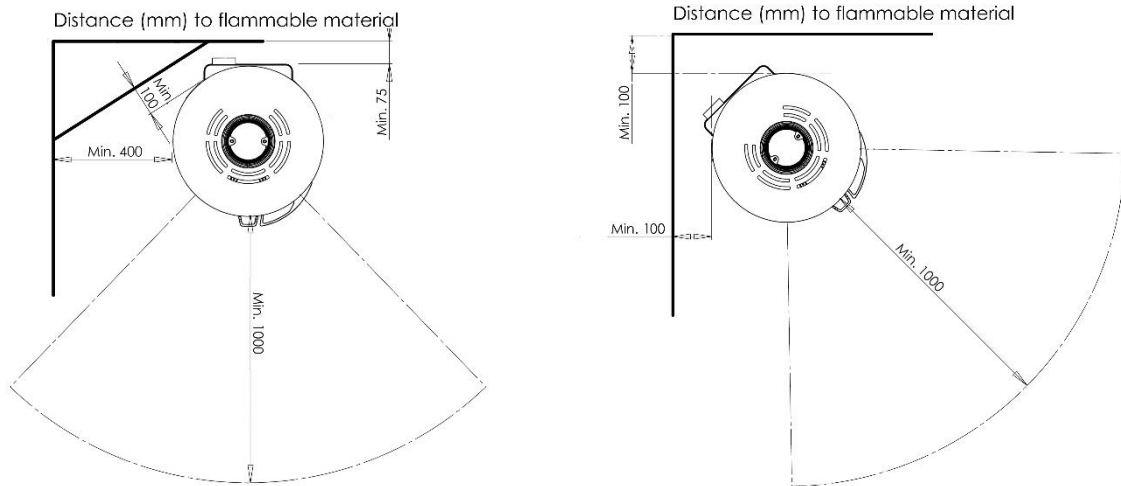

To secure access to inspection openings and enough air for the combustion, there needs to be a distance of at least 8 cm to the wall behind. However, to ensure easy access during service and cleaning, we recommend keeping a distance of min. 10 cm to the wall. You must be prepared to dismount the flue pipe and turn the stove during the yearly inspection and by maintenance.

If the Aduro H2 is to be placed close to flammable material such as a wooden floor or carpet it must be placed on a non-flammable base. The floor plate should extend for at least 30 cm in front of the Aduro H2 and 15 cm on each side – measured from the combustion chamber opening.

Please ensure that all local rules and regulations are complied with, including CE marking of the exhaust connector. Additionally, distance requirements to flammable material for the exhaust connector must be respected.



The Aduro H2 must be installed on a floor with the adequate load-bearing capacity. If the existing construction does not meet this requirement, appropriate adaptation measures must be taken (e.g. a load-distributing plate).

2.2 Pipe connection

Aduro H2 leaves the factory with the flue outlet mounted on the top. If you require the flue outlet on the back, remove the round circle from the rear cover at the upper rear of the stove and then exchange the exhaust connector (located on the top outlet above the stove) with the cover plate (that covers the rear outlet). The top outlet is finished with the plate that lies in the ash pan. We recommend that you place a thin gasket between the flue pipe and exhaust branch. A flue pipe with an internal diameter of 150 mm should be used for Aduro stoves. Aduro H2 is tested and approved for use with an uninsulated fluepipe of minimum 100 cm.

2.3 Connection to a brick chimney

If the stove is being connected to a brick chimney, the rear outlet should be used, or a curved flue pipe via the top outlet. After measurement, a hole is made in the chimney in which the pipe sleeve is placed, and fireplace mortar is used to seal it in place. The stove is placed in position and the flue pipe is put in place. A thin gasket is placed between the flue pipe and the pipe sleeve to seal the joints. The flue pipe should protrude into the pipe sleeve but must not block the opening in the chimney (see the illustration below).

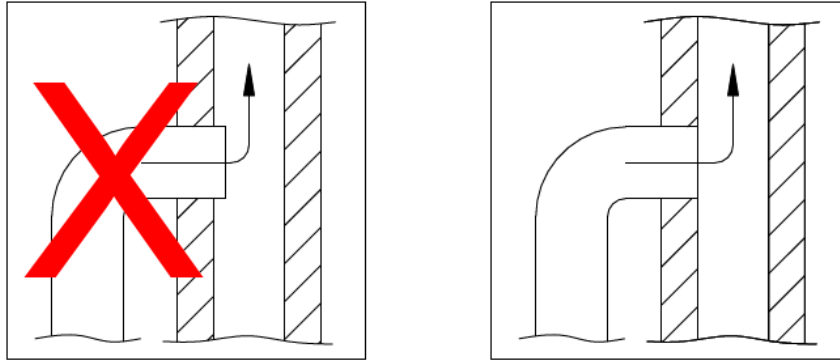

The Aduro H2 can be connected to a chimney to which other heat sources are connected.

2.4 Supply of combustion air

All wood burning stoves need constant supply of air to ensure a clean and efficient combustion. This is often a problem in modern energy-efficient houses that are very tight. Therefore, the Aduro H2 is equipped with external supply of combustion air, where the air to the combustion is supplied from the outside and directly into the wood burning stove. Air from outside can be provided through a channel, which is connected to the connecting pipe under the combustion chamber. The amount of air needed for combustion is 25 m³/h.

The connecting pipe has an external diameter of 78 mm, to which you need a pipe with a diameter of 80 mm. If the pipework is more than 100 cm, or if there are bends on the tube, the resistance in the pipe increases significantly. Negative pressure outside on the sheltered side of the house can also affect the resistance of the pipe significantly. In these situations, the pipe should have a diameter of minimum 100 mm. It may also require a stronger chimney draft, which you can achieve by installing an Aduro DraftOptimizer. You can easily test the resistance in the pipe by opening a window close to the stove, disconnect the external air supply and then light up the stove. If the combustion looks different than before, there is too much resistance in the external air supply. If the pipe work is further than 1 m the pipe diameter must be increased to 100 mm and a correspondingly larger wall valve must be chosen. In warm rooms the channel should be insulated with 30 mm mineral wool covered with a damp-proof course (plastic). It is important that the lead-in between the pipe and the wall (or floor) is sealed with jointing compound. You can eventually use the complete Aduro fresh air kit.

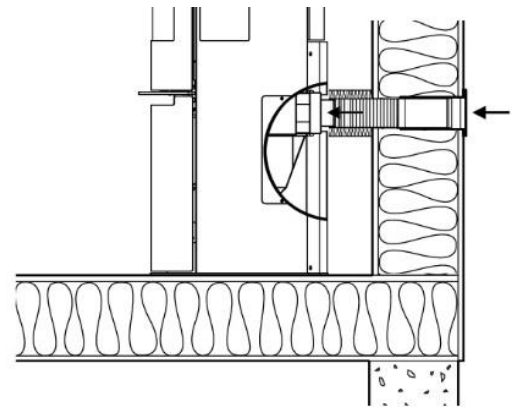

2.5 Aduro Hybrid App

It is possible to control Aduro H2 in three ways:

1. Through the control panel on the stove.
2. Through the app Aduro Hybrid and the Wi-Fi module “Aduro” in the near of the stove
3. Through the app Aduro Hybrid when the Wi-Fi module is connected to the router and connected to Aduro Cloud. When your stove is connected to Aduro Cloud, it can be controlled remotely.

The app Aduro Hybrid is free and can be downloaded from App Store or Google Play.

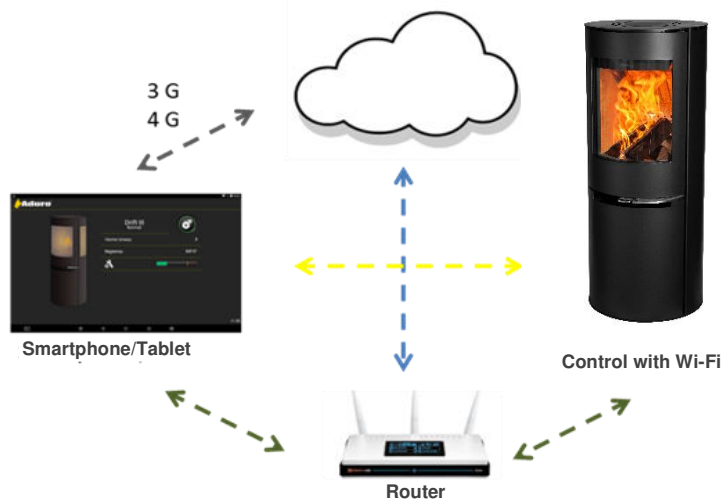

Configuration of the app

1. Connect the stove to power outlet (see section 2.6).
2. Download the Aduro Hybrid app from either Google Play (Android) or App Store (Apple).
3. Follow the instructions in the guidance of the app or from our website www.adurofire.com/aduro-hybrid under “Frequently asked questions” and “Wi-Fi connection”.
4. The serial number for operation (5-6 digits) and password for the app (10 digits) can be found on the label inside the bottom front door. It looks like this:



5. Software and app are now updated to the newest version.
6. Now you are connected and able to operate using the app.

App features

The app has several features to choose from; heat level, desired room temperature, and timer/week program. The timer/week program makes it possible to plan, how the stove should run during the week.



The frontpage of the app shows:

1. Power status
2. Heat level
3. Smoke temperature
4. CO level (Safety measurement which measures whether there is smoke in the back of the system). A green bar is OK. If the bar reaches yellow, the hybrid stove will lower its heat level to 1. If the bar reaches red, the stove will turn off itself.

The CO sensor is located by the pellet inlet to prevent the stove from firing when the chimney draft is not sufficient. The CO sensor could be affected by the pellets. Some pellet bags have a high level of CO that can affect the sensor up to 24 hours after loading the stove with pellets. If this problem occurs, you can open the door to the pellet container and add fresh air to the room until the CO level has dropped.

2.5.1 How to connect the stove to the internet

For successful connection, there must be a stable Wi-Fi signal where the stove is installed. In case of weak or unstable signal, the use of the stove could be affected.

It is recommended to install the stove where there is a maximum Wi-Fi signal with 3 out of 3  or 4 out of 4 . Your smartphone/tablet must be connected to the local Wi-Fi network. If you experience any difficulties controlling the stove via the smartphone/tablet, it is due to the fact that the smartphone/tablet has a control system that does not meet our requirements (See 2.5). If you are able to control the stove through the smartphone/tablet but can't connect the stove to the Wi-Fi router, the router is too old and/or the signal too weak. If this is the case, we recommend you to buy a new router with a strong signal and a Wi-Fi amplifier that is located somewhere between the router and the stove.

If other electronic devices work well in the house, but the hybrid stove can't be connected, it is due to the fact that the hybrid stove requires a stronger Wi-Fi signal than other electronic devices.



At our website you can find more information on how to configure the Wi-Fi. Go to <https://www.adurofire.com/aduro-hybrid/> under “Frequently asked questions” and “Wi-Fi connection”.

2.6 Electrical connection

Aduro H2 comes **with approx. 1.5 meter of cord with an Euro-plug**, that should be connected to a 230V / 50Hz outlet. Power consumption during operation is approx. 33 watts. The cord must be positioned so it is not in contact with hot surfaces or pointed objects.

2.7 Register your stove on Aduro Cloud

We highly recommend that you register your hybrid stove on our cloud www.adurocloud.com as soon as the stove is connected to your Wi-Fi router. By registering your stove, you will have access and overview of your stove's data – what it does, how it burns (graphs, statistics, logs, settings) etc. When your stove is registered,

it is helpful for you as a user, but also helpful for us and the craftsmen, if something happens to the stove, or when it needs the yearly service visit from a professional. In [Aduro Customer Service](#) you can find a guideline on how to access the cloud. You can access the service center [here](#).

3. Lighting a fire in the Aduro H2

You can light the fire using just pellets or light it manually with wood – or a combination where you put firewood in the combustion chamber and use the pellets to light the fire. We recommend a combined usage, since firing with wood gives a higher temperature which burn the remains of the pellets.

Important safety information

- The Aduro H2 will become warm during use and therefore it should be treated with all necessary caution.
- Never keep easily combustible fluids such as petrol in the near of the Aduro H2.
- Never use easily combustible fluids to light the fire in the Aduro H2.
- When lighting a fire, it is important to get the fire burning fast. If the fire does not start quickly and wood only smoulders, it can cause strong smoke formation and in worst case cause an explosive ignition of the flue gasses, which can damage the stove.
- Never empty the ash pan when the Aduro H2 is warm. Embers may still be found in the ash pan for up to 24 hours after the fire has gone out. Please wait to empty the ash pan until you are sure that there are no embers in the ash.
- The door should be kept closed while the Aduro H2 is in use. While lighting the fire, the door can stand ajar for the first few minutes.
- The pellet function stops if the door is opened.
- When putting logs in a hot stove, you must always open the primary air intake and make sure that the wood ignites within 2-3 minutes. If the wood does not ignite, add some ignition products and ignite them manually.
- In the event of a chimney fire: Close all the dampers on the Aduro H2 and call the fire-fighting service.

3.1 Damper

The stove is equipped with a damper under the door, which regulates the combustion air: primary, secondary, and tertiary air supply. The primary air is used at the beginning to get the fire going, the secondary air keeps the fire burning evenly, and the tertiary air ensures that flue gasses are burned. You must always add secondary and tertiary air, while firing the stove. According to our experiences regarding the use of the pellet function, we recommend that the damper is always completely closed to achieve the optimum combustion of the pellets.

The damper allows you to adjust the Aduro H2 according to the chimney draft and the heat output, you require. The longer the damper is pulled out, the more air is added and the more powerful the combustion. The illustration below shows the stove seen from the front with the dampers indicated. Use edge of door to read position of inlet air:

1: Fully open primary, secondary, and tertiary air inlet. This position can be maintained with the Aduro key, which must be placed in the two holes.

2: Closed primary air inlet, fully open secondary- and tertiary air inlet.

3: Closed primary air inlet, half way closed secondary air inlet and fully open tertiary air inlet.

4: Closed primary and secondary air inlet, fully open tertiary air inlet.

5: Regulator pushed all the way in. All air inlet closed (only used when burning wood pellets).

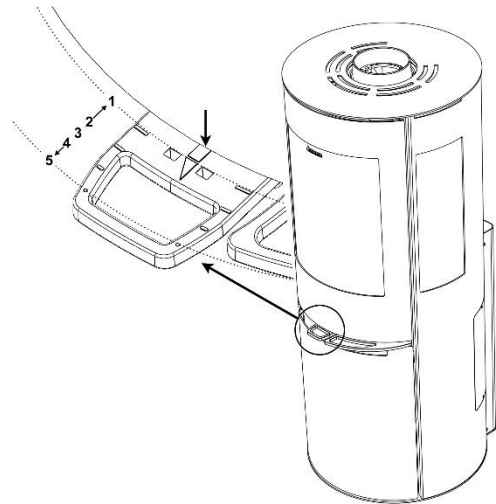

3.1.1 Secondary air supply

In normal circumstances, the Aduro H2 should be working with this damper between 60 % and 100 % open (the damper is placed between position 2 and 3). You should never close the air intake so far that the flames are extinguished. There should always be visible flames in order to achieve clean and efficient combustion. A too low supply of air can lead to bad combustion, high emissions and a bad efficiency.

If you wish to fire the stove with the lowest effect possible – around 3 kW – you must close the secondary air supply almost completely 45 minutes after the wood has been put in. At this point there are only few flames and the stove can burn clean by using the tertiary air from behind in the stove.

3.1.2 Primary damper

When you add a new log, the primary damper should be opened until the fire is burning properly. In order to utilize the fuel to the fullest extent, the embers should have burnt for so long that it is necessary to open the primary damper for approx. 2 minutes to get the new log to burn.

In order to reduce the risk of ash falling from the stove when the door is opened to add more fuel, it is a good idea to open the primary damper for approx. 1 minute before the door is opened. This increases the draft through the stove and reduces the risk that ash will drop on the floor.



If you overload the Aduro H2 and burn more than approx. 3.1 kg wood per hour, there is a risk that the lacquered surface of the stove will become discolored and eventually fall off. The stove can be repainted, but this is not covered by the manufacturer's guarantee. In the same way, any other damage to the stove caused by overloading will not be covered by the warranty. If the smoke temperature exceeds 350 degrees, it can damage the gear motor.

3.2 Aduro-tronic

The patent-applied control Aduro-tronic is a manually operated mechanical start-up device, which works without the use of electricity and automatically regulates the combustion. All you have to do is put dry wood in the stove and activate the control system. Aduro-tronic does the rest, leaving you to enjoy the flames, the benefits of efficient combustion, and a reduced firewood usage up to 40 %. For further information, go to www.adurofire.com.



3.2.1 How to operate Aduro-tronic

When lighting with wood only

When lighting a fire in the Aduro H2 for the first time, the maximum amount of primary air will be needed to light the fire. For that reason, the primary damper can be kept “forcibly open”. This is done by pulling the primary damper forward as far as possible and then fixing it with the Aduro Key (see illustration). When the stove is warm and a layer of embers has been created on the bottom of the combustion chamber, the Aduro-tronic can be set to the automatic position, i.e. the Aduro Key can be removed. Alternatively, you can leave the door ajar the first minutes during lighting the fire (without the key).

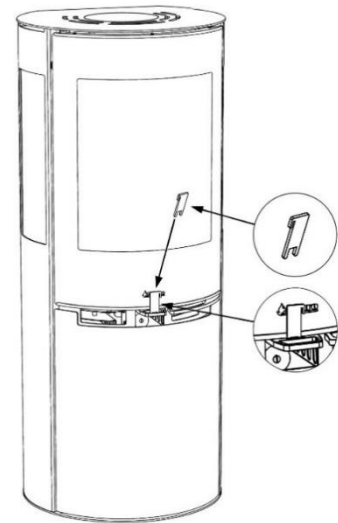

When stoking

Each time fresh wood is put in the stove, a precise amount of primary air will be allowed in for the first few minutes. What's more important is that the primary air is not allowed in for too long. This is to ensure optimum combustion. The Aduro-tronic control will ensure intake of primary air at the right tempo. The automatic is activated by pulling the primary damper out each time fresh wood is put in the stove. The automatic closes then the primary air gradually.

Regulation of the Aduro-tronic control

The control is pre-set to close the primary air intake within 6 minutes. This setting has been used during testing at the Danish Technological Institute using a standard chimney and ‘standard’ sized logs (approx. 30 cm long, 10x10 cm thick) with maximum moisture content of 18%. In practice, such circumstances can differ, which is why the Aduro-tronic control can be adjusted to your circumstances. If you want a slower intake of primary air (e.g. for a slower flue draft, larger sized wood or for longer intervals between stoking), adjust the screw on the front of the control level using a small allen key to slow closure rate. If the screw is turned to the right closing time is increased and if turned to the left closing time is reduced.

3.3 How do I light the fire in my Aduro H2?

During transportation, it may happen that the exhaust deflector in steel falls out of place. Therefore, before using the stove, please make sure that the exhaust deflector is properly placed (on the hooks or fastened to the bolts depending on the model) for optimum combustion and preventing soot on the glass.

If you only want to use your Aduro H2 with wood, the hybrid stove has a damper (see illustration) for closing the pellet combustion manually. The pellet function does not work when this damper is closed. The damper is necessary, as you need to close the air to the pellet combustion to achieve the most optimum combustion of the wood. However, if using both pellets and wood, the damper must be open (pulled forward).

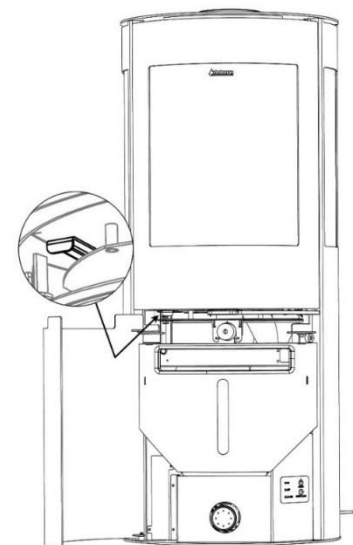

3.3.1 The first time a fire is lit

During the first firing, which should be carried out using approximately 1 kg of wood, the stoking door must be left slightly open and must not be closed until the stove is cold. This is to prevent the sealing rope sticking to the stove.

The first few times the Aduro H2 is used, there may be some smoke and unpleasant odours from the Aduro H2, which is fairly normal. This is caused by the heat-resistant paint hardening. Make sure there is sufficient ventilation during this stage. It is also important not to let the fire burn too fiercely the first 2-3 times, so that the Aduro H2 has time to expand slowly. You should also be aware that the stove may make clicking sounds as it heats up and cools down – rather like pouring boiling water into a sink. These are caused by the great differences in temperature to which the materials are being exposed.

3.3.2 Lighting the fire manually with firewood

The fire lighting method is very important for starting combustion quickly and efficient.

1. Pull the damper under the door fully out so that primary, secondary, and tertiary air supply is completely open.
2. Place a log of wood crosswise in the combustion chamber and put 2 firelighters close to the log. Light the firelighters and quickly put a new log close to the firelighters and several small logs at an angle above it. Air must be able to reach the firelighters, but the logs should be touching to “warm” each other.
3. Keep the door approx. 1 cm ajar, until the glass is too hot to touch. Then close the door. When there are distinct, visible flames and the fire has taken hold, close the primary air intake.



The control handle will get warm when the Aduro H2 is in use. Please use the glove provided when you operate the Aduro H2.

3.3.3 How do I add pellets?

Place the enclosed funnel in the opening of the pellet box and add the pellets. The pellets are distributed with a poker in the box to make use of the entire capacity (approx. 13 kg of pellets).

By the first use, the augers must be filled with pellets:

Open the door to the combustion chamber and lift out the front of the brazier (the black cast iron cone with the Aduro logo) so you can see the pellets. Close the stove's door. Press and hold the **AUGER** button and the augers will start transporting the pellets (only at **OFF** mode yellow button). After approx. 12 minutes when you press and hold the **AUGER** button, the auger pipe will be filled with pellets. Stop pressing the **AUGER** button when the pellets are about 2 cm under the auger pipe's top edge. Insert the brazier and close the stove's door. In section 5 you will find an overview of the different alarms.



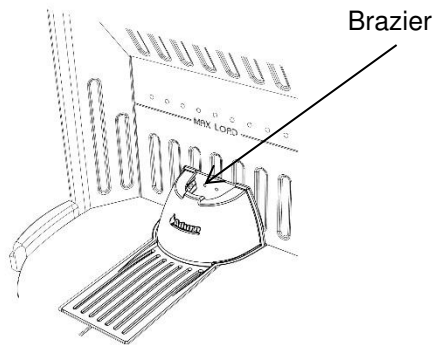

3.3.4 Lighting the fire with pellets

Before the pellet function of the stove is turned on, you should ensure that there are enough pellets underneath the brazier. You can do this by moving the brazier to the side. If there are pellets up to around 1 cm under the edge of the auger tube, there are enough pellets. You can now put the brazier back in place. Remember to check that it is placed correctly and fits tightly. Then, you can turn on the stove.

Push the **ON/OFF** button and wait until the **ON** button displays a constant green colour. The lighting of the fire will then start automatically, and the pellet burner will start. When the stove is lighting, the combustion chamber will be filled with smoke until the ignition starts. After approx. 6 minutes flames should appear. Normal use should be achieved after 15-20 minutes.

When the smoke temperature reaches 90 degrees, the stove will shift from the “warm up mode” to “normal mode” and continue with the last settings. You can manually change between 3 heat levels without using the app by pushing the logo with an auger, which is placed directly under the **ON/OFF** button on the display.

- Step 3 (100 % operation): ‘ON button’ lights green constantly.
- Step 2 (50 % operation): ‘ON button’ flashes quickly.
- Step 1 (10 % operation): ‘ON button’ flashes slowly.

When you want to switch of the pellet burner, push the **ON/OFF** button or use the app.

If you experience that the stove does not turn on in the first or second attempt but instead shows the alarm “ignition failed”, it is important that you do not try to turn on the stove again. Instead, wait until there is no more smoke in the combustion chamber, and then move the brazier to the side and scrape the pellets away if they have accumulated. You can now put the brazier back in place. Remember to check if it is placed correctly. Then, you can turn on the stove again. The alarm “ignition failed” is often caused by an insufficient chimney draft. You can create chimney draft by igniting some paper or small pieces of firewood - this can sometimes remove pockets of air in the chimney.

The pellet function can burn up to 24 hours on a full pellet container at level 1, 12 hours at level 2, and 8 hours at level 3. The stove is capable of running day and night, if pellets are added in time.

3.3.5 Lighting the fire with wood and pellets at the same time

Cold stove

Put dry wood in the combustion chamber - just as if you wanted to start the stove manually (see section 3.3.1). However, you won’t need any firelighters. The fire is lid with pellets. It will be an advantage, if you start with a closed air inlet until the fire is burning in the pellet burner. After this, you can open the air inlet for

easier lighting of the firewood. When the logs have caught fire and the smoke temperature is about 280 degrees, the pellet supply will stop automatically.

The stove in pellet operation

When the stove is in pellet operation, you can always add firewood – you just have to remember to close the door within 3 minutes. Open the door carefully and the pellet supply will stop and the ALARM flashes red. Add firewood of the correct quality and respect the MAX load line. Close the door again. The stove will now continue combustion of pellets. When the logs are burning and the smoke temperature is about 280 degrees, the pellet supply stops automatically. After this, the stove will change to WOOD BURNING mode.

It may occur that the temperature rises above 300 degrees when using pellet operation on heat level 3. If this happens, the pellet supply stops automatically and the stove will shift to wood burning mode. To avoid this, reduce the amount of pellets at heat level 3. This is done in the service menu by choosing “auger”.

If you use the function "Heat Level" on the app and want the stove to restart automatically on pellets when the wood has burned out, you can set the Aduro Hybrid on standby mode with just 1 click on the button (see illustration). The stove will now be in standby mode and await a smoke temperature below 100 degrees before it starts the pellet combustion and ignites again. However, if you use the function "Desired Room Temperature", the Hybrid will start automatically again when the smoke temperature is below 100 degrees.

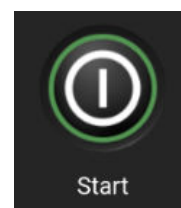

IMPORTANT!

If the door to the combustion chamber is open for more than 3 minutes, the pellet combustion will shut down and must be started again by pushing **ON/OFF**. The stove starts when the smoke temperature is below 100 degrees. If the stove **flashes** green **ON**, it means that the stove will start, but is waiting for the smoke temperature to be below 100 degrees C or timer.

When you want to switch off the pellet burner, push the **ON/OFF** button. If you open the stove door during operation, the red **ALARM** will light. If you close the door before 3 minutes, the pellet burner goes back to **ON** mode automatically.

3.4 How should I use my Aduro H2?

The Aduro H2 is intended for *intermittent* combustion. This means that each stoking should burn down to embers before new logs are added.

In order to obtain the best possible combustion, you should regulate the effect/heat output with the fuel. Burning small logs provides more powerful combustion than burning large logs as the surface area is greater and more gas is released. The amount of wood in the combustion chamber is another factor that affects combustion. The optimum combustion is achieved by adding two pieces of logs. If you want an enhanced effect, you can add more logs. The nominal heat output is reached by burning approx. 1.5 kg per hour, divided between 3 pieces with a length of approx. 21 cm.

If you experience problems lighting the fire or the fire dies after a short time, it can be due to the following reasons:

- The firewood is not dry enough. The firewood should have a moisture content of max. 18%.
- There is a negative pressure in the house.

- The smoke outlet from the outside may be blocked from sooth. This can occur after chimney sweeping. Control the smoke outlet.
- The used amount of wood may have been too small. Therefore, the embers were too weak and cold to light the next load of wood.

3.5 Recommended fuels

3.5.1 Wood and wood briquettes

Wood that has been stored indoors has a tendency to become too dry and will burn too quickly. We recommend that you fell the wood in the winter, when a lot of the moisture in the wood will have been drawn down into the roots. In order to achieve optimum combustion, the wood's moisture level should not exceed 18 %, which roughly corresponds to storing the wood under cover outdoors for one year. The moisture level of the wood can be measured using a moisture meter or by applying washing up liquid to one end of the log and blowing air in the other end. If the wood is dry enough, soap bubbles will appear. The wood should be chopped into logs with a diameter of approx. 10 cm and a log length of max. 39 cm.

Correct firing provides optimum heat output and maximum economy. At the same time, correct firing prevents environmental damage in the form of smoke and malodorous fumes and also reduces the risk of chimney fires. Well-seasoned wood fuel is essential for correct use. Make sure your fuel is kept dry. If the fuel is wet, a large proportion of the heat will be used to vaporize the water, and this energy will disappear up the chimney. It is clearly not only uneconomical to fire with wet fuel but also, as mentioned above, increases the risk of producing soot, smoke and other environmentally damaging by-products.

Burning varnished wood, impregnated wood, chipboard, paper and other waste is strictly forbidden. Burning these materials will damage the environment, the Aduro H2 and your own health. Fossil fuels must not be used.



The brazier must not be removed during use with either wood nor pellets (doesn't apply when conducting a fast cleaning under the brazier to clean out ash and cinders). Never use wood with nails and other objects that can damage the auger carrying the pellets. Never place pellets in the combustion chamber. Pellets must be supplied from the pellet container.

3.5.2 Pellets

You can only use Ø6 mm pellets with a maximum length of 40 mm – type ENplus quality A1. We recommend that you use pellets of a good quality – and preferably bright pellets instead of dark pellets. The quality of the wooden pellets has a direct influence on the noise level, the efficiency, and the cleaning interval of the stove. It is important that the pellets are kept dry, as moist pellets can reduce the nominal heat output by up to 50%.

When the firing season is coming to an end, it is important to completely remove all pellets from the pellet container and the augers. If you don't do this, material damage can occur when you start using the stove again.

At our website www.adurofire.com/aduro-hybrid you can find more information.

4. The chimney

The optimum combustion is achieved at a constant chimney draft of 10-14 Pascal (Pa) measured in the flue pipe above the stove (when having a smoke exhauster). However, with natural draft (chimney without smoke exhauster) the draft in the chimney will be between 18-25 Pa when conditions are optimum. There are many factors that affect the chimney draft, including the outside temperature, wind strength, and surrounding buildings. There are no requirements with respect to specific chimney heights, but a chimney must be tall enough to provide a good draft. If the recommended chimney draft is not achieved, there may be problems with smoke out of the door by firing.

Data for chimney calculation	Wood
Flue temperature at [20°C]	273
Chimney draft at testing power [mbar]/[Pa]	0.13/13
Flue gas mass flow [g/s]	5.7

4.1 Inadequate draft in the chimney

If you experience poor draft in the stove after the installation, please make sure that there is nothing in the chimney to restrict the smoke and that no nearby buildings or trees affect the winds around the chimney.

If the chimney is too short, leaks, or is inadequately insulated, there may be problems with the chimney draft (let the chimney sweep assess this). The draft should be sufficient during the ignition phase when the stove/chimney is cold to provide a clean combustion and prevent smoke leakage. Therefore, we recommend a chimney draft around 5 Pa in the ignition phase.

Once the ignition is a success and the smoke temperature is rising, it is important that the chimney draft reaches a stable area around 18-25 Pa in operation (1 hour after ignition) when the chimney/stove is hot. The draft in the area of 18-25 Pa when the stove is hot is essential in order to achieve an optimum and clean combustion and avoid problems such as pellet accumulation and smoke leakage. Therefore, we recommend that you measure your chimney draft when the chimney is cold and when it is hot after 1 hour in operation.

In practice, the chimney draft will differ – especially in cold condition. Therefore, the best indication of the chimney draft is to measure the draft when it is hot. If the chimney sweep judges the draft to be sufficient, but you still have problems lighting a fire in “wood mode”, try extending the fire lighting phase by using more thin pieces of kindling and 1-2 firelighters, so that the chimney gets thoroughly warm. The chimney will not draw at optimum effect until it is warm. When a layer of embers has been formed, add 2-3 dry logs.

When in "pellet mode", the stove will not be able to ignite and instead give the alarm “failed ignition” if there is not enough chimney draft in the ignition phase. If you experience that the stove does not turn on in the first or second attempt but instead shows the alarm “ignition failed”, it is important that you do not try to turn on the stove again. Instead, wait until there is no more smoke in the combustion chamber, and then move the brazier to the side and scrape the pellets away if they have accumulated. You can now put the brazier back in place. Remember to check if it is placed correctly. Then, you can turn on the stove again. The alarm “ignition failed” is often caused by an insufficient chimney draft. You can create chimney draft by igniting some paper or small pieces of firewood - this can sometimes remove pockets of air in the chimney.

If it is impossible to establish a sufficiently natural chimney draft, the chimney can be fitted with a smoke exhauster, e.g. Aduro DraftOptimizer.

4.2 Chimney and Smoke

If you experience smoke coming out of the stove or the start section of the smoke pipe, it could be due to certain weather conditions. On stormy or cold winter days or if the chimney has not been used in a while, a cold plug can be created in the chimney, meaning the natural draft will be at its minimum.

If the chimney is cold and cold plugs are created, you may experience smoke leaks during the ignition and startup phase. In this situation there can be more smoke than usually in the combustion chamber and some of it might leak out of the stove. Therefore, if you have a cold chimney that has not been used for a while, we recommend that you use some wood sticks to heat the chimney and eliminate the cold plug before turning the pellet function on.

4.3 Draft and pellet combustion

The pellet combustion is affected by the draft in the chimney. If necessary, it is important to reduce or improve the draft with a damper in the chimney or with a smoke exhauster, e.g. Aduro DraftOptimizer, if the draft is too high or insufficient.

You can connect Aduro DraftOptimizer to Aduro H2 and control it automatically to ensure optimum draft. For further information, go to www.adurofire.com.

Aduro Hybrid has certain standard settings when it comes to the speed of the auger and the fan, and in order to achieve the most efficient / clean pellet combustion, it may sometimes be necessary for the user to adjust these settings to customize the stove to their own installation such as chimney, smoke pipe, external factors from the outside etc. If you're interested in knowing more about the app's features/functions, calibration, and various FAQ's, then you can read more about it on our website www.adurofire.com.

Below 3 examples of pellet combustion, depending on the draft level:

Optimum flame



Flame generates high quantity of "sparkles" = the chimney draft is too high

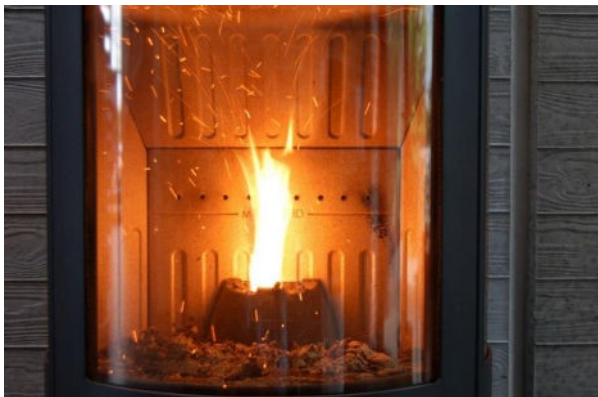

Flame is low and brazier is overflown = the chimney draft is not sufficient



You can partly compensate for an inadequate chimney draft by increasing the fan speed on the hybrid stove. This is done in the service menu of the app.

5. Control of Aduro H2

Aduro H2 has the following ALARM modes where pellet delivery must be stopped immediately:

- SMOKE SENSOR: smoke sensor defect.
- SHAFT SENSOR: shaft sensor defect.
- TERMO: shaft sensor too hot.
- DOOR CONTACT: door open.
- PELLETT DAMPER: damper closed.
- EXIT: defect exit for external auger.
- FUEL: smoke temperature too low after more than an hour of operation – no fuel?
- LIGHTING: smoke temperature not reached after two attempts to light the fire.
- CO: CO (carbon monoxide) level is too high.

Here the **ALARM** will light red. When the cause of alarm has been rectified, the stove can be started by pushing **ON/OFF** twice.

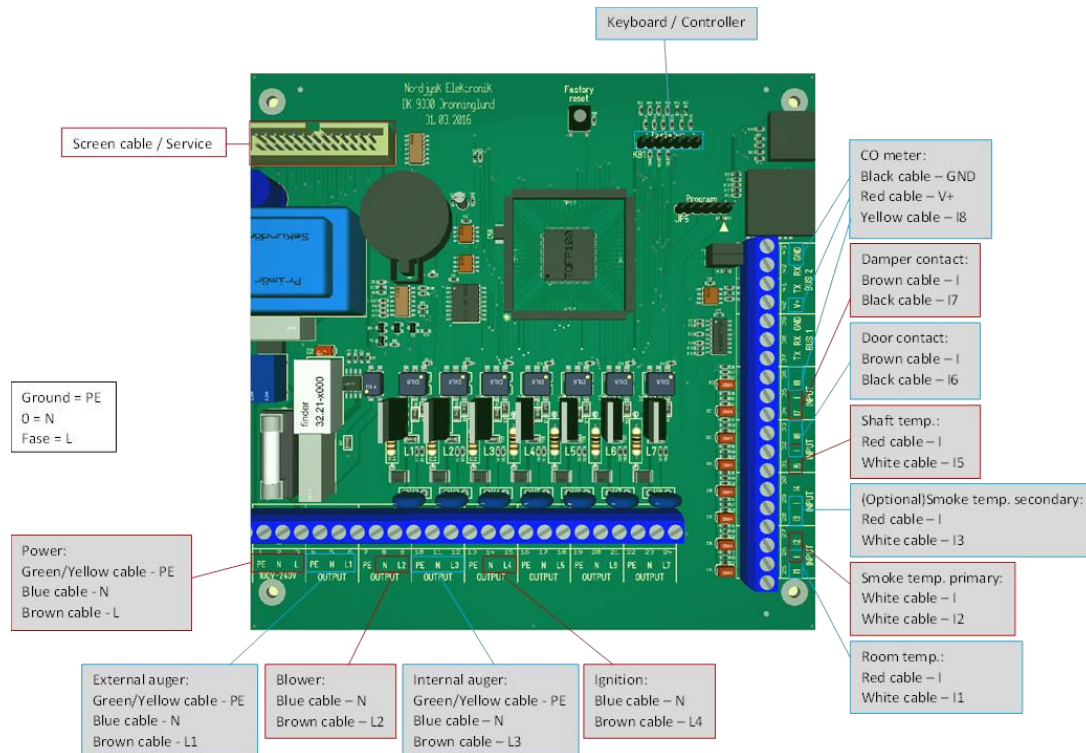

The development within phones and electronics continuously provides new possibilities and demands for updates and developments of the app. When you buy an Aduro Hybrid stove, updates of the app and control system are included 5 years after purchase. After this, charges may apply for updates.

6. Maintenance of the stove



All maintenance and cleaning of the Aduro H2 should be carried out when the stove is cold and power disconnected.

6.1 Daily maintenance – when using pellets

When you add pellets, you should brush the brazier free from of ashes and cinders. Open the door to the combustion chamber and lift the front of the brazier (the black cast iron cone with the Aduro logo). Brush the ashes and the cinders through the grate to the ash pan. Avoid brushing ashes and cinders down into the pellet auger. Put back the front of the brazier.

Empty the ashpan when needed.

Brazier

We recommend two types of maintenance during the week: a short cleaning while the stove is lit (cannot last more than 3 minutes because of the sensor in the door) and a thorough cleaning where the stove is turned off and cold. We recommend that you conduct the short cleaning 2 times a day and the thorough cleaning every 4 days.

During the short cleaning, the stove must be cleaned under the brazier. We recommend that you use gloves. By using a tong or a similar tool, you can move the brazier to the side and clean out ash and cinders. Put the brazier back in place. During the thorough cleaning, the fireproof tiles must be removed, and the auger and the combustion chamber must be vacuumed thoroughly.

6.2 Regularly maintenance – when needed

Ashes

Empty the ashpan before it gets completely full. Always leave a layer of ashes in the stove because it insulates and makes it easier to light a fire.

Remove the brazier and clean the top auger for ashes with a vacuum cleaner. This is done easiest by making a "paper ring" of paper roll, which is laid around the opening of the auger. Then press the vacuum cleaner muzzle down towards the "paper ring" so it fits tightly. After this, the ashes can be vacuumed up.

Glass

Wet wood, insufficient chimney draft, and wrong use of the hybrid stove can leave soot stains on the glass. They can easily be removed using a damp cloth that you dip in cold ash and rub on the sooty glass. Special cleaning agents are also available to remove soot from glass, e.g. the Aduro Easy Clean pad. The pad neither scratches nor damages the glass, and it can be used multiple times. Water or other cleaning agents are not necessary.

It is common maintenance to tighten the glass fittings and the hinges shortly after the stove has been installed as well as to check if the gaskets are properly placed.

Pellet container

Burn all pellets and brush the container clean.

6.3 Periodically maintenance – after about 500 hours of use

If the stove is placed in dusty surroundings, it can be necessary to clean the ventilator. Clean the brazier for ash and cinders, e.g. with a scraper. Clean the air pathway for electrical igniter for ash and cinders that might be covering the hole placed on the left side of the tube under the brazier, e.g. using a small, straight screwdriver.

For further information regarding maintenance of the stove, please go to www.adurofire.com.

6.4 Yearly maintenance

The yearly maintenance must be conducted by a professional. Contact your local Aduro GO partner for further information as rules for chimney sweeping and stove maintenance differ from area to area.

The chimney must be maintained and swept according to local rules.

The Aduro Hybrid stove must be inspected after one year for cleaning and adjustment. Hereafter, maintenance must be conducted by an Aduro certified professional every other year or for every 2,000 kg pellets burned.

6.5 Other maintenance

Gaskets

With time, gaskets around glass and door will wear. We recommend that you inspect them regularly. If leakages appear, they must be replaced.

Combustion chamber

The fireproof tiles in the combustion chamber eventually wear out and should be replaced when the cracks are more than 0.5 cm. The durability of the tiles depends on how often and how intensively the stove is used. You can change the tiles yourself. They are available as a ready-to-use set. For further information, go to www.aduroshop.com.

How do I remove the Bauart spring?

All Aduro stoves are fitted with a “Bauart” safety spring. The mechanism ensures that the door of the stove closes automatically. The “Bauart” spring is only a law requirement in Germany.

How to remove it:

- If you wish to remove or replace the spring with a new one it is possible to cut the spring using a pincer. It is advisable to hold the spring with pliers or cover it with a cloth or other device to absorb the tension, as the pieces might spring out right after the cut.
- Please note that the spring is in tension when the door opens, so make sure to protect yourself during fitting and removal.
- After that, close the hole in the stove with the enclosed self-tapping screw.

Cleaning the Aduro H2

The stove's surface is treated with a heat-resistant Senotherm® paint, which will stay at its best just by being vacuumed with a small, soft mouthpiece or dusted with a soft, dry cloth. Do not use spirit or other solvents, as they will remove the paint.



Do not clean the hybrid stove with water. If the stove is exposed to moisture, the stove may develop rust.

The inside of the Aduro H2 and the flue pipe can be cleaned through the door or alternatively through the cleaning aperture in the flue pipe/chimney. The upper fireproof tile (the exhaust deflector) can be removed. To allow free access to the top of the Aduro H2 and the flue pipe, remove the exhaust deflector in steel. Cleaning of the inside of the Aduro H2 and the flue pipe should be undertaken at least once a year, or more

frequently if necessary, depending on how often the Aduro H2 is used. This work can also be carried out by the chimney sweep or your local Aduro GO partner.

Repairing the surface

Aduro stoves are painted with a heat-resistant paint that can withstand temperatures up to 500 degrees. If the surface of the stove gets scratched or worn, it can easily be renewed using this type of paint. Everybody can repair the surface and obtain a perfect result. The paint is available in black metallic from your local dealer or at www.aduroshop.com.

Spare parts and unauthorized alterations

You may only use original spare parts for your stove. All forms of unauthorized alterations to the stove are strictly forbidden, as the stove will no longer comply with the approved specifications. At www.aduroshop.com you can buy original spare parts for your stove.

7. Accessories

For Aduro stoves we offer a wide product range of accessories to fulfil the experience: Companion sets, firewood baskets and buckets, fireplace grid, briquette buckets, floor hearths in glass and steel, flue pipes, Aduro Easy Firelighter, and Aduro Easy Clean pad. For further information, go to www.adurofire.com/accessories.

8. Right of complaint

In accordance with the Danish Sale of Goods Act, the right to claim is valid from the date of purchase of the stove. Receipt with date is valid as proof.

All pellet stoves may require adjustment of combustion air and auger speed in order to optimize function and in order to reach effective and clean combustion. Aduro AS and service partners can monitor and adjust stoves on the Aduro cloud. However, it is only possible if the stove is connected to the cloud via Wi-Fi. Aduro AS can therefore not treat complaints regarding function and combustion if the stove is not online.

If you have difficulties getting the stove online, it can be because of your local Wi-Fi network, router or phone setup. You find guidance about Wi-Fi on adurofire.com – but it is not the responsibility of Aduro AS to secure connection. You can purchase a service visit in order to get the stove online before you can hand over complaints regarding combustion and function to Aduro. Alternatively, some Aduro resellers offer this assistance.

The right of complaint does not cover:

- Damages resulting from incorrect installation and use of the stove, overheating and wrong or missing maintenance of the stove etc. (including the annual service visit).

- Consumable service parts (glass, gaskets, firebricks, handles, slides, painted surfaces, electrical igniter, sensors/switches, brazier, cast iron grate), which are subject to normal wear and tear. You can buy these parts in our webshop www.aduroshop.com.
- Damages caused by electrical surcharge, (condensation) water in and around the chimney, too much or too little draught in the chimney and missing maintenance/cleaning.
- Mounting or demounting in connection with warranty repairs.
- Transportation costs in connection with repairs within the warranty period.
- Damages to the stove caused by external influences or damages caused by the stove on other objects.

9. Disposal of your Aduro stove

When disposing your stove, metal, vermiculite, ceramic glass, and electronics must be sorted separately. Dispose hereafter the materials according to the regulations at your nearest recycling depot.